

## ALPHADECKSTAGING

### Installation Instructions for the AlphaDeck Staging System

#### Step 1 - Preparation

A. Before setting up this system, determine the location of the stages and all the parts you will need.

B. Read through the installation instructions and make sure you have all the parts you need.

#### Step 2 - Leg Assembly

A. Determine the height of stage required in order to choose the right size legs:

- If you are dealing with an uneven ground, you will need to take that into consideration and ensure you have the steel legs to accommodate different heights.
- If outdoors, ensure the ground is hard enough to support the stage without concerns of the legs sinking.

B. If the stage is being set at a height less than 24 inches, then you can affix the leg to the stage unit at this time. To do so, insert the top of the leg into the base unit and use a cotter pin to connect by pushing it through both holes and clasp it on the other side.

C. If you require a telescoping adjustable leg or a taller staging system you will use the larger 1 ¾ inch square tube as a telescoping sleeve by affixing the leg to the rubber base foot. You will line up the leg with the base foot and place a cotter pin through the third hole and clasp on the other side (as done in 2A). You will then set the appropriate height needed for the stage by sliding the 1 ½ inch steel leg into the telescoping sleeve and affix by placing a cotter pin through and clasp on the back side. You must ensure that you always leave at a minimum 6" overlap to provide strength and stability. Finally, you will insert the leg into the stage and affix using a cotter pin.

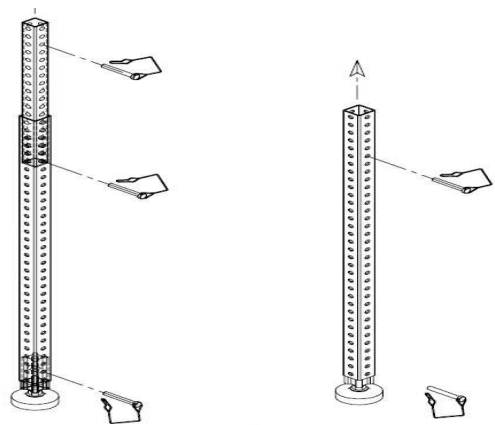

### Step 3 - Setting Up the Stages

- A. Determine the location of the first stage.
- B. After you have one stage assembled with all four legs, you are ready to start adding on to your staging system. First you are going to place this first unit in the back left corner and start building out from there.
- C. Ensure that all cotter pins are facing out, so that the clasp is on the outside of the steel legs.
- D. Ensure that the slotted sides of the connection system (female) are facing towards the outside of the staging system, and the locking side (male) is facing in.
- E. First, line up the stages so that they face the same way as the first one, with the two lock sides (male) facing the way in which you want the deck to expand (towards the front and along the back row). The slotted sides will be facing the assembled deck and the back of the stage.
- F. Insert two legs as shown in the diagram and affix as done before. The back row will only require two legs per deck.
- G. Attach the second deck to the first by sliding the oval shaped slotted opening over the round peg.
- H. Once aligned correctly, use the hex wrench to tighten, by inserting through the surface hole and turning clockwise to engage the cam lock. Once it has been turned, the decks will be locked into place.
- I. Upon completion of the back row of decks, start the second row by affixing two legs as shown in the graphic to the side, and follow steps C and D above.
- J. Continue assembling decks as shown in the diagram, by inserting one leg into far corner as shown and pin in place with cotter pin. You will continue assembling in this fashion, locking the decks together by tightening the cam locks on each deck as shown above.
- K. You will continue to assemble the decks in this fashion as you move towards the front of the staging system. The final deck will need just one leg to complete the assembly of the system. All the stages should be locked together with cam lock and double-checked after installation.

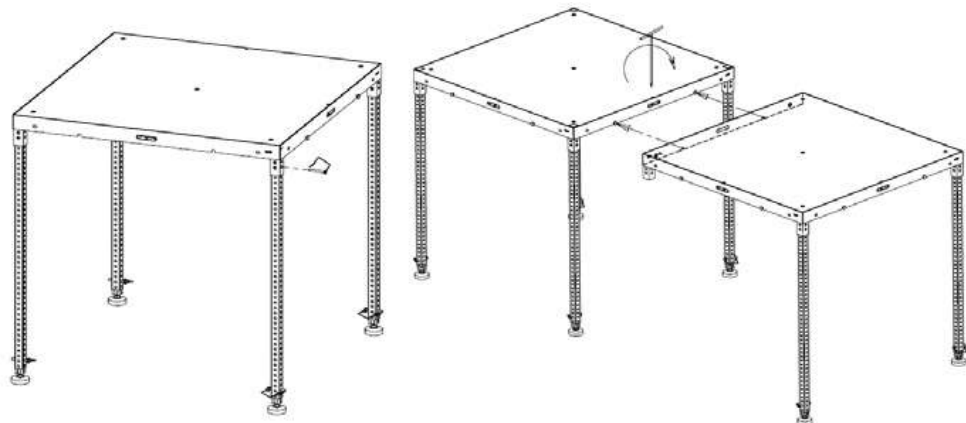

### Step 4 - Guard Rail Installation

- A. The outside dimension of a standard guard is 4', Attach the guard rail to the female side of the first row of stages.
- B. Use a bolt and nut to lock the guard rail on the stage.
- C. Use a clamp and quick clip to make connection between guard rails.
- D. Use a quick pin (special pig tail) to lock the horizontal bar to the guard rail.

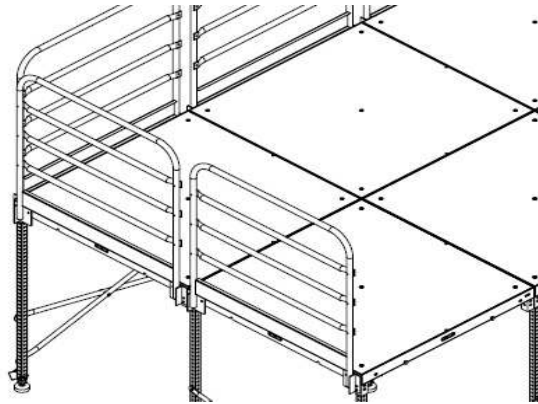

### Step 5 - Diagonal Brace Assembly

- A. Diagonal bracing is required on stages with heights over 30". Brace each corner and every third bay along each side, connecting with a nut and bolt.
- B. The bolt space of the diagonal brace will be :
  - 12" with legs at 48" center line.
  - 18" with legs at 46" center line.

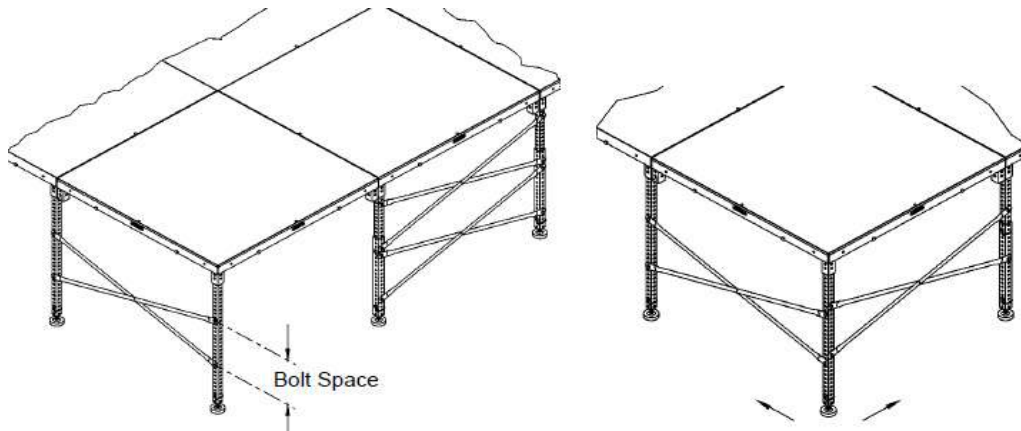

C. The Diagonal Brace is strongly recommended to maximize the stability of your staging system.

D. When bracing the legs, a common leg should be braced in both directions as the figure.

E. The amounts of brace used on the stages area will depend on the final conditions.

## Step 6 - Stair System Assembly and Connection

A. Refer to the stair's drawing to assemble stair.

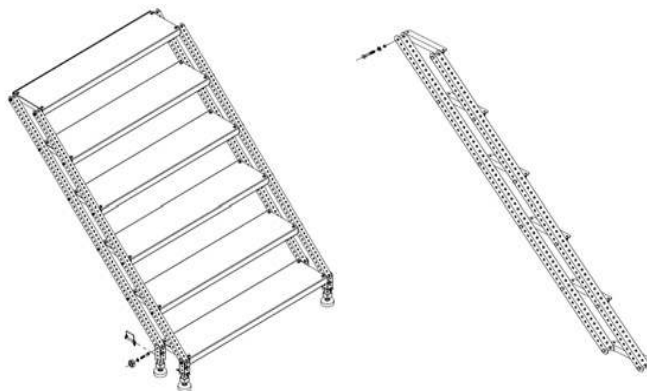

B. Bolt each stair on the bracket.

C. The first stair will be connected to the stage on the male side.

D. Bolt the stringer to the adjustable rubber foot.

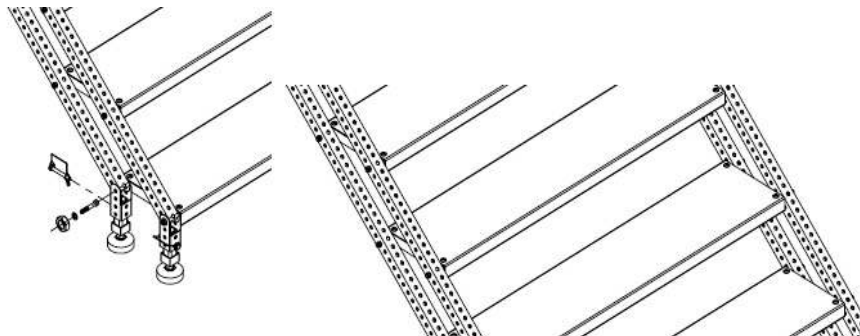

E. Using a bolt and nut to lock the stairs and stringers together.

F. Bolt the top part of the male side of the last stair. Rotate the cam lock to lock the stage and stair together.

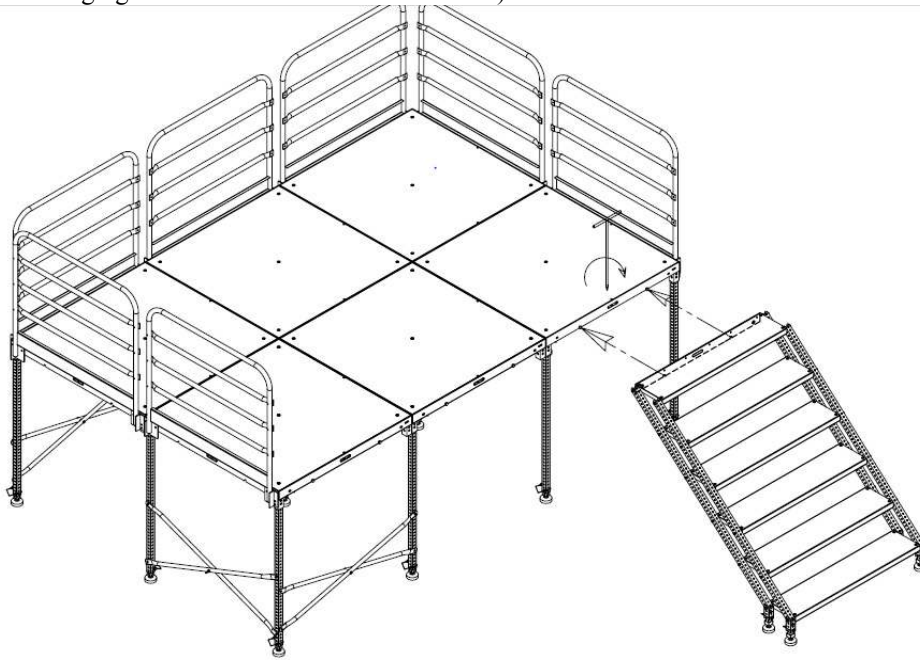

### Step 7 - Ramp Connection

- A. Ramp Deck is used to allow equipment and wheelchair access to the staging.
- B. Combine ramps and regular decks to create the appropriate length and slope of the ramp, depending on stage height and layout.
- C. The ramp's assembly is same with stage, the male side on the ramp can lock with the female side of stage by means of cam lock easily, and the special requirement can be made on demand.

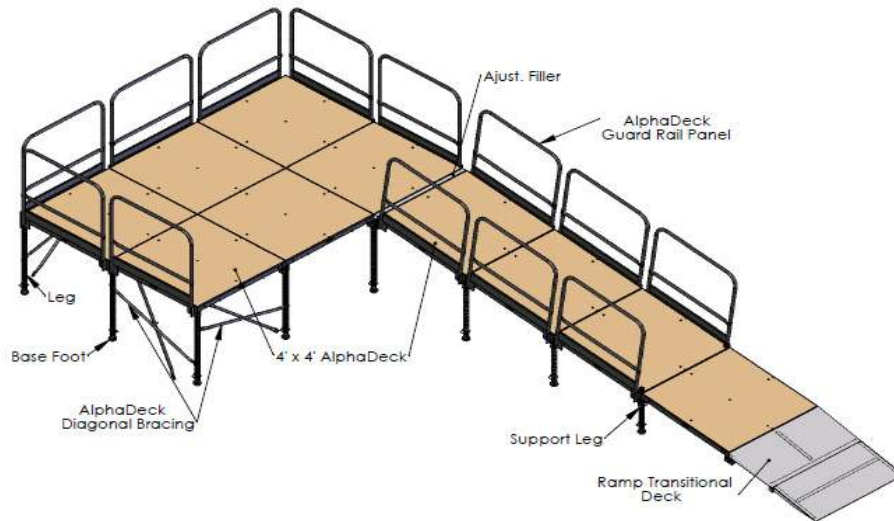

### Step 8 - Hand Rail on Folding Stair

- A. Use bolts and nuts to assemble the handrail parts as in the diagram below.
- B. Set up the hand rail with right side and left side respectively.
- C. Bolt the hand rail to the stringer.

